

MULTIWALL POLYCARBONATE INSTALLATION GUIDE

MAIN CHECKS

- UV or IR side is facing outwards (UV side has laser etching on the edge and printed film on the surface)
- Fastening should not be overtightened and should be spaced to accommodate positive/negative loading specifications
- Aluminum/Vented Tape should be applied to the top and bottom of the flutes
- 1/8" per 4 feet to allow for thermal expansions
- Multiwall polycarbonate sheets must be ordered the same length as your roof, they CANNOT be butted end to end or end to side
- Attachment profiles should run the full lengths of the sheet, they CANNOT be butted end to end or end to side

POLYETHYLENE FILM

The front and back faces of the polycarbonate sheet are protected by a polyethylene film. To minimize damage, do not completely remove film until installation is complete. Printed side designates UV protected side. Sheets may be delivered with colored polyethylene tape covering the ends. Remove the polyethylene tape and replace the top end with solid aluminum tape and the bottom end with vented tape.

STORING POLYCARBONATE PRODUCTS

Polycarbonate products should be stored out of direct sunlight, in a dark environment. Sunlight can cause the polyethylene to stick to the polycarbonate surface, making it difficult or impossible to remove. Store polycarbonate in a well-ventilated, dry environment to keep moisture from building in the flutes. When storing outside, sheets should be covered and out of sunlight. Do not cover with PVC materials.

CLEANING THE POLYCARBONATE SURFACE

1. Rinse the surface of the polycarbonate
2. Use warm water with dish soap and a soft cloth to wipe away dirt
3. Rinse the surface with water
4. Wipe dry with paper towels or a soft cloth

Abrasive materials and chemicals could cause damage to the surface of polycarbonate products.

STRUCTURAL RECOMMENDATIONS

- Sheets should be installed with the flutes/ribs running the same direction as the structures slope
- A minimum slope of 7% or 5° is recommended to facilitate water drainage
- Flutes/Ribs should run vertical when applied in a wall or window.
- Purlin and rafter spacing is dependent on load requirements and sheet specifications (call before planning structural support)
- Cold bend radius differs by sheet specifications
- Do not exceed 3" of overhang from structure
- All structural framework should be complete before installing sheets or panels

SHEET PREPARATION

FILM REMOVAL, TAPING AND PLACING THE U PROFILE

1. Remove the polyethylene film from the bottom (non UV side) of the polycarbonate sheet
2. Peel the UV protected side (printed side) back 3-4 inches from each side
3. If the ends of the sheet are covered with polyethylene tape, remove it and follow step 4
4. Apply solid aluminum tape to the top and vented aluminum tape to the bottom of the panel
 - *Vented tape can be used on both top and bottom this negates air insulation

U-PROFILE

- The U-profile should be cut to the width of the polycarbonate sheet using a circular saw
- Drill 1/8" weep holes every 12 inches to allow water and condensation to leave the panel
- After applying tape to the top and bottom of the sheet, cover with an aluminum or polycarbonate U-profile

SHEET INSTALLATION USING POLYCARBONATE H-PROFILE:

- The U-profile should be cut to the width of the polycarbonate sheet using a circular saw
- Drill 1/8" weep holes every 12 inches to allow water and condensation to leave the panel
- After applying tape to the top and bottom of the sheet, cover with an aluminum or polycarbonate U-profile

FASTENING INSTRUCTIONS

1. Pre-drill holes through the polycarbonate sheet 1/16" larger than the fastener
2. Using a self tapping fastener with a galvanized neoprene washer, fasten every 24" through the pre-drilled hole, at least 1" into the structure

IMPORTANT POINTS WHEN FASTENING:

- Fasten every 24" through the polycarbonate sheet
- Polycarbonate profiles are not designed to be fastened
- Aluminum profiles have specified recommended fastening points
- Fastening should be done one to two inches away from the edge of the polycarbonate sheet
- If fastening to a purlin, position fastener approximately 6 inches from the side edge of the sheet
- Fasten until the galvanized neoprene backed washer sits flush to the sheet or profile (tight enough not to move out of position but not depress)
- Overtightening screws can cause leakage and weaken the strength of a sheet

CUTTING AND DRILLING:

Polycarbonate sheets and panels can be cut with fine-toothed (8-12 teeth/inch) circular, jig, table, or band saw. Blades should be certified for plastic cutting. To reduce vibration, polycarbonate panels should be clamped when cutting. Polyethylene film should be kept on the panel while cutting. Cuts using power tools should be done at a high speed moving slowly down or across the panel. Edges can be trimmed with a very sharp box knife. Use an air compressor to clear any debris from within the flutes of the panel. Holes should be pre-drilled through polycarbonate sheets, larger than the fastener, using a power drill and multi-purpose drill bit (This allows for thermal expansion around the hole). Self-tapping screws are recommended. The extra space around the fastener left will be covered by the neoprene backed washer.

SEALING MULTIWALL POLYCARBONATE:

Multiwall polycarbonate sheets and systems are dry fit systems. We do not recommend sealing within the system. When flashing on to polycarbonate, 100% silicone should be used on connection points. If sealing is desired, add beads to the inside/back wall of the polycarbonate profile before sliding it into place (This is not required). No sealant that gets on polycarbonate will be able to be removed. (Expansion and contraction rates of silicone and polycarbonate are different, eventually they will pull away from one another)

COLD BEND RADIUS:

Thickness (mm)	4	6	8	10	8	10	16
Thickness (in)	5/32	1/4	5/16	3/8	5/16	3/8	5/8
Structure (walls)	2 wall			3 wall			
Min. Bend Radius	30"	39"	59"	69"	69"	79"	110"

The cold bend radius, defined above, is the amount a panel can be curved without adding heat. Each panel has a set minimum radius, it should not be exceeded.

ALWAYS DOUBLE CHECK:

- UV or IR side should be facing towards the sun (the UV side will be indicated on the polyethylene film as well as etching into the edge of the sheet)
- Fastenings are not overtightened and are spaced to meet specifications
- Attachment profiles need to run the full length of the sheet
- Use only compatible silicone sealants
- Flutes should run vertical on the structure
- Apply aluminum tape along the top flutes and vented tape along the bottom flutes
- Leave 1/8" per 4 feet to allow for thermal expansion
- Polycarbonate profiles should not butt against one another

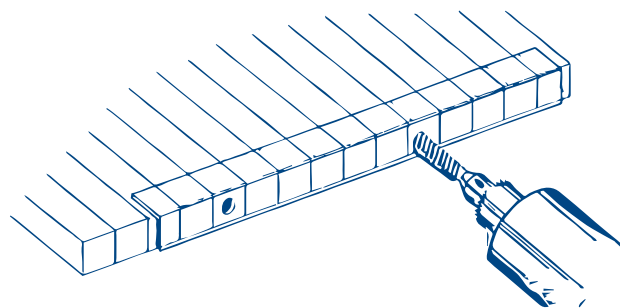

U PROFILE

The U Profile is designed to protect and further seal the edge of the polycarbonate sheet from water, bugs, and dust. After vented and aluminum tape is applied to the upper and lower ends of the polycarbonate, fit the U Profile over the tape at each end. The profile should cover the full width of the sheet. The shorter leg of the polycarbonate is UV protected and should face up.



F PROFILE

The F Profile is designed to seal the edge of the polycarbonate sheets. This profile should span the full length of the panels and fit firmly to create a finished edge look to the structure. The longer top side of the Polycarbonate F profile (shown below in red) is UV protected and should face up.



R PROFILE

The R Profile is designed to connect two polycarbonate sheets at a corner of a vertical installation. The R Profile is positioned at 180° and can be closed to make a 90°. Install by inserting the polycarbonate sheet into the R Profile running parallel with the flutes. Using the R Profile to create a roof ridge is not recommended. Polycarbonate profiles are not designed to butt against one another.

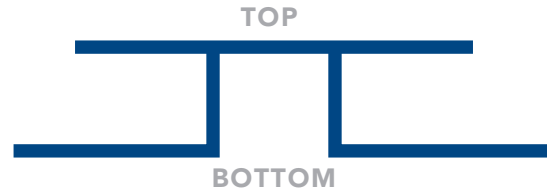

H PROFILE

The H Profile is designed to connect two polycarbonate sheets together parallel to the ribs of the sheets. Do not fasten into the profile. Fastening should be done directly into the polycarbonate sheet using recommended sheets and washers. The shorter side of the H Profile (shown in red) is UV protected and should be placed facing up. This profile is not recommended for curved structures.

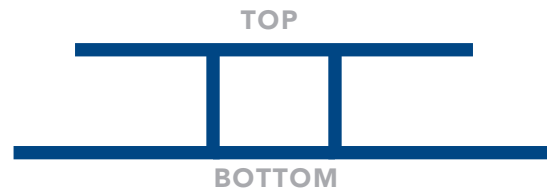

SNAP H PROFILE

The Snap H Profile is designed to snap together, connecting two polycarbonate sheets and holding them in place. Fastening should be done directing into the polycarbonate sheet (not through the profile) using the recommended screws and washers. The shorter side (shown in red) of the profile is UV protected and should be placed facing up. Applicable to sheet thicknesses ranging from 4-10mm.

